

# H PARTS LIST

## HAS™ Rear Air Suspension

LIT NO: SP-149

DATE: August 2016

REVISION: I

### CONTENTS

DESCRIPTION	PAGE	DESCRIPTION	PAGE
Parts Lists		Selection Guides	
HAS™ for Vehicles Equipped with Air Disc Brakes		▪ U-bolts . . . . .	7
▪ 21K • 23K • 40K • 46K . . . . .	2	▪ Slipper Pad . . . . .	7
HAS for Vehicles Equipped with Drum Brakes		▪ Spring Seats . . . . .	14
▪ Tandem 36K • 40K • 46K . . . . .	4	Special Tools . . . . .	13
▪ 40K LH . . . . .	8	Notes . . . . .	13
▪ Single 12K • 15K • 19K • 21K • 23K . . . . .	10		

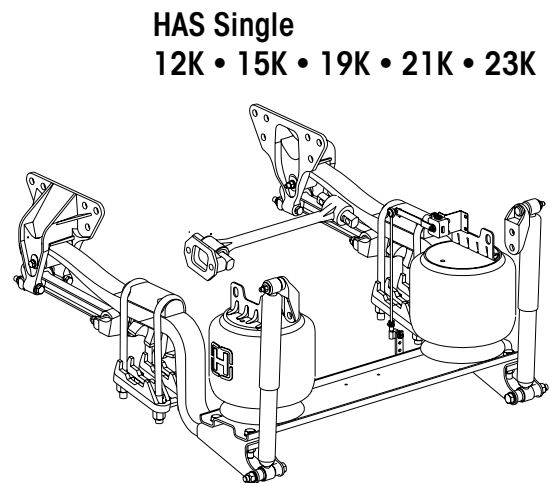
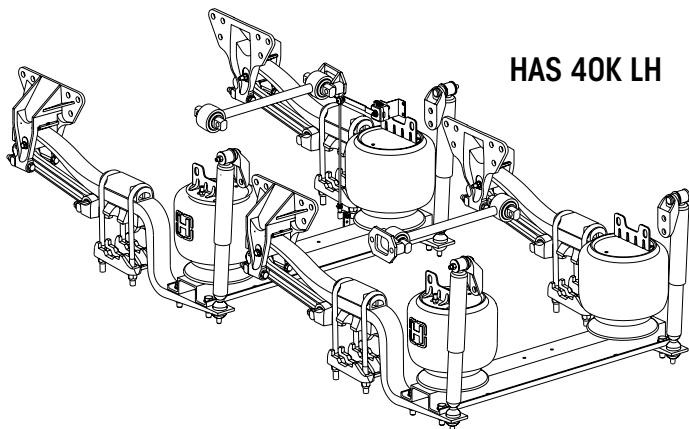
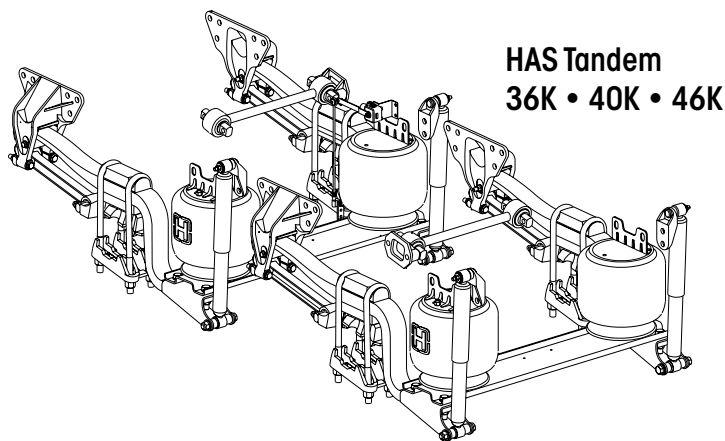

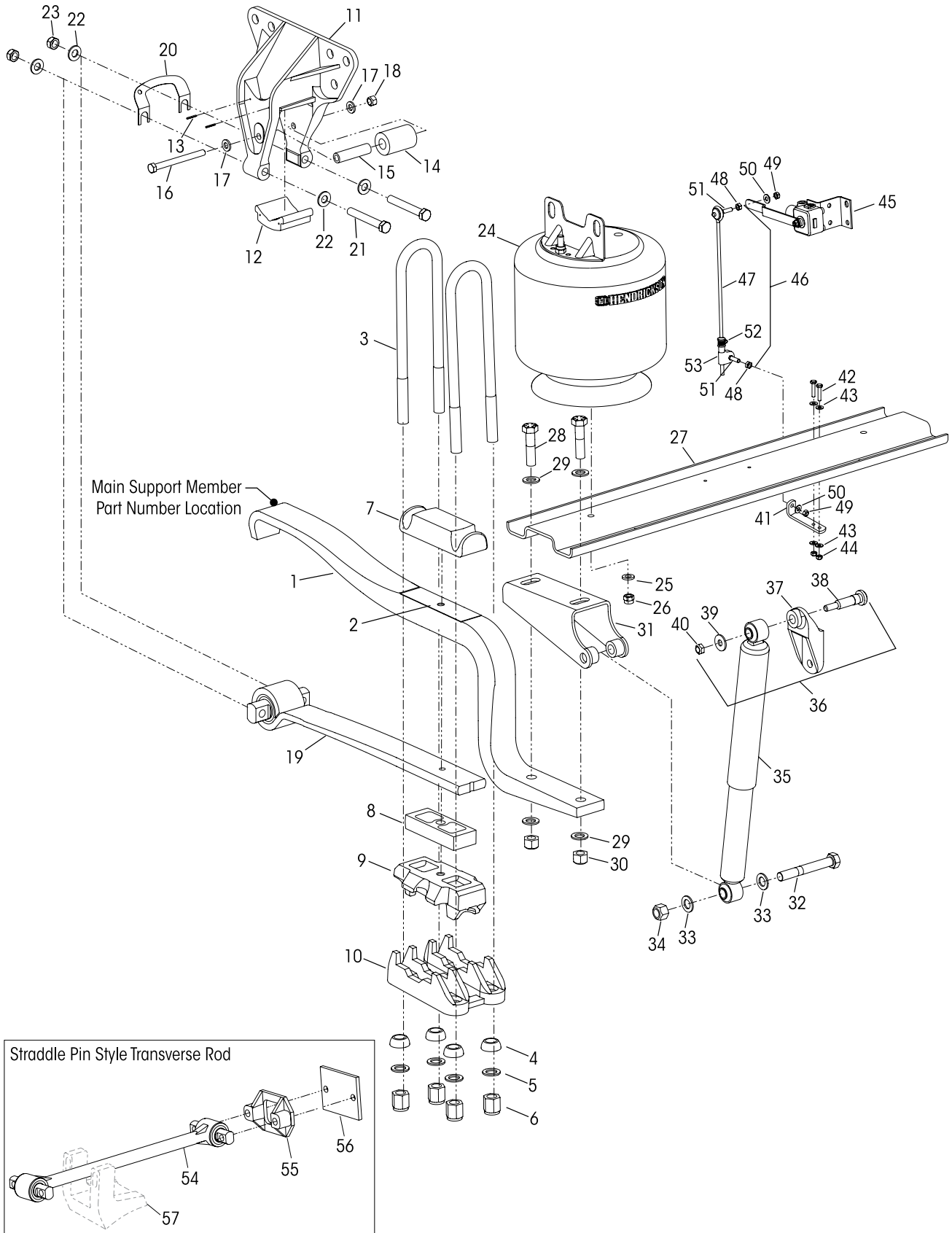



# HAS™ 21K•23K•40K•46K with Air Disc Brakes

KEY NO.	PART NO.	DESCRIPTION	VEHICLE QTY.	KEY NO.	PART NO.	DESCRIPTION	VEHICLE QTY.
1	59193-000	Main Support Member, Includes Key No. 2 <i>See Part No. Location on Page 2</i>	4	28		¾"-10 UNC Bolt	4
2		**Delrin Liner	4		50764-003	3½" Length	
3		7/8"-14 UNF U-bolt, <i>See Selection Guide on Page 7</i>	4		50764-005	3" Length	
	48718-157	<b>U-bolt Fastener Service Kit, Two U-bolts,</b> Includes Key Nos. 4-6		29	22962-001	¾" Flat Hardened Washer	16
4	48574-000	7/8" Spherical Washer	16	30	49842-000	¾"-10 UNC Locknut	8
5	22962-002	7/8" Flat Hardened Washer	16		57356-000	Lower Shock Bracket Assembly, Includes Key Nos. 31-34	4
6	57347-000	7/8"-14 UNF U-bolt Nut	16	31	57355-000	Lower Shock Bracket	4
7	56805-000	Top Pad	4	32	50764-002	¾"-10 UNC x 3½" Bolt	4
8	48531-020	Spring Seat Spacer - 1¼" Height	4	33	22962-001	¾" Flat Hardened Washer	8
9		Spring Seat Assembly, <i>See Selection Guide on Page 15</i>	4	34	49842-000	¾"-10 UNC Locknut	4
10		Axle Bottom Cap	4	35	60670-005L	Shock Absorber	4
		LHF/RHF/LHR/RHR		36	57322-002	Upper Shock Bracket Assembly, Includes Key Nos. 37-40	4
		<b>Meritor</b> RT 40-145, RT 46-160		37		**Upper Shock Bracket	1
		LHF/RHR		38	50368-000	½"-13 UNC x 3¾" Serrated Shank Bolt	4
		<b>Meritor</b> SSSD, SQ-100; <b>Dana</b> DS-402/451		39	22962-031	½" Flat Hardened Washer	4
	50216-000	2°-9.5° Pinion Angle		40	49846-000	½"-13 UNC Locknut	4
	50222-000	10°-12° Pinion Angle			57430-000	<b>HCV Linkage Lower Bracket Kit</b> Includes Key Nos. 41-44	
11	58425-001	Frame Hanger Assembly, Includes Key Nos. 12-13	4	41	56789-000	HCV Linkage Lower Bracket	1
	56557-005	<b>Slipper Pad Service Kit, One Hanger,</b> Includes Key Nos. 12-13		42	56935-001	¼"-20 UNC x 1" Bolt	2
12	56929-000	Slipper Pad	4	43	22962-028	¼" Flat Hardened Washer	4
13	58287-001	1" Lock Pin - ⅝" Diameter Retainer Lock Pin	8	44	49983-000	¼"-20 UNC Locknut	2
	49175-013	<b>Rebound Roller Kit, Axle Set,</b> Includes Key Nos. 14-18		45	57977-000	Height Control Valve	1
14	57989-000	Rebound Roller	4	46	58994-XXX	HCV Linkage Assembly, Specify Length, Contact Hendrickson for part no. Includes Key Nos. 47-53	1
15	57988-000	Rebound Bolt Spacer	4	47		**Linkage Rod, Specify Length	1
16	24531-015	½"-13 UNC x 5½" Hex Bolt	4	48		**5/16"-18 UNC Jam Nut	2
17	22962-014	½" Flat Washer	8	49		**5/16"-18 UNC Locknut	2
18	49846-000	½"-13 UNC Locknut	4	50		**5/16" Flat Hardened Washer	2
19	53350-000	Single Leaf Spring	4	51		**5/16"-18 UNC Stud	2
20	49689-000	Shim - 1/16"	4	52		**Linkage Rod Clamp	1
21	32043-005	5/8"-11 UNC x 4½" Bolt	8	53		**Adjustable Linkage Rod Joint	1
22	22962-004	5/8" Flat Hardened Washer	16	54	60218-000	<b>****Two-Piece Transverse Torque Rod Kit,</b> Includes Bushings	2
23	47764-000	5/8"-11 UNC Locknut	8	55	22186-000	Transverse Torque Rod Frame Bracket	2
24	50898-002	Air Spring Assembly	4	56	45045-003	Back up Plate	2
25	22962-014	½" Flat Hardened Washer	4	57		*Transverse Torque Rod Axle Bracket	2
26	17700-010	½"-13 UNC Nylocknut	4		70867-001	P-80 Lubricant - 10 ml (Not Shown)	Per Bushing
27	57317-001	Cross Channel - 40" Dowel Pin Centers	2				

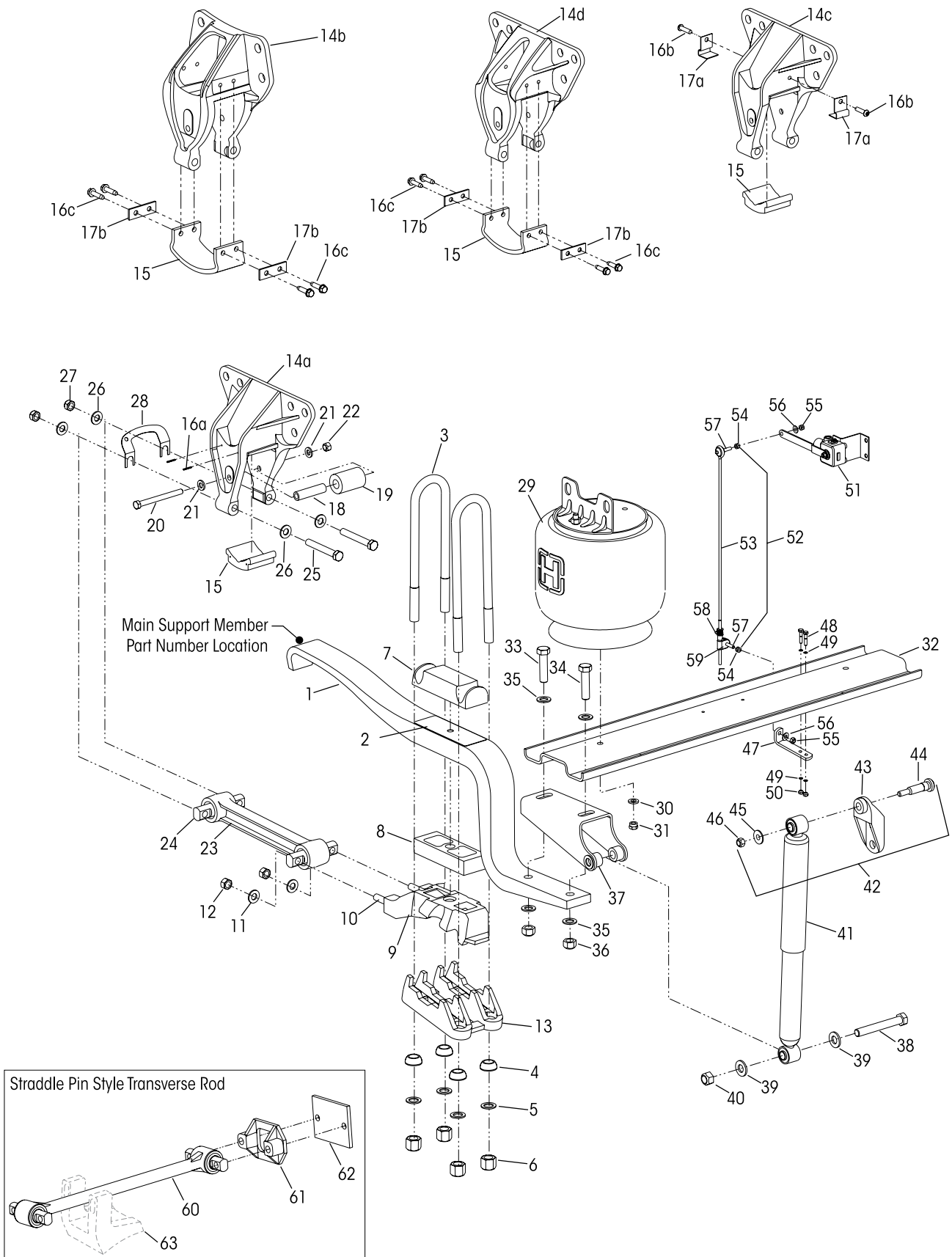



# HAS™ Tandem 36K • 40K • 46K Equipped with Drum Brakes

KEY NO.	PART NO.	DESCRIPTION	VEHICLE QTY.	KEY NO.	PART NO.	DESCRIPTION	VEHICLE QTY.
1		Main Support Member, Includes Key No. 2 <i>See Part No. Location on Page 4, 46K Severe Service Kit on Page 6</i>	4	17		Retaining Bracket or Plate, <i>See Selection Guide on Page 7</i>	8
	56940-000	HAS 36K, 1.75" Thickness		a	57566-000	Retaining Bracket	
	56931-000	HAS 40K Low Profile, 1.875" Thickness		b	50597-000	Retaining Plate	
	56943-000	HAS 40K, 1.875" Thickness			49175-013	<b>Rebound Roller Kit, Axle Set,</b> Includes Key Nos. 18-22	
	56934-000	HAS 46K Low Profile, 2" Thickness		18	57988-000	Rebound Bolt Spacer, <i>Replaces 47458-000</i>	4
	56946-000	HAS 40K, 46K, 2" Thickness		19	57989-000	Rebound Roller, <i>Replaces 48883-000</i>	4
2	47905-000	Delrin Liner	4	20	24531-015	½"-13 UNC x 5½" Rebound Bolt	4
3		7/8"-14 UNF U-bolt, <i>See Selection Guide on Page 7</i>	8	21	22962-014	½" Flat Hardened Washer	8
	48718-157	<b>U-bolt Fastener Service Kit, Two U-bolts,</b> Includes Key Nos. 4-6		22	49846-000	½"-13 UNC Locknut	4
4	48574-000	7/8" Spherical Washer	16	23		Longitudinal Torque Rod Assembly Includes Key No. 24	4
5	22962-002	7/8" Flat Hardened Washer	16		48411-006	HAS 36K • 40K	
6		U-bolt Nut	16		62007-365	HAS 46K, <i>Replaces 50376-001 Torque Rod and 57256-000 Bushing</i>	
	50765-000	7/8"-14 UNF Locknut		24	47691-000L	Torque Rod Bushing	8
	57347-000	7/8"-14 UNF Nylocknut		25	32043-005	5/8"-11 UNC x 4½" Bolt	8
7	56805-000	Top Pad	4	26	22962-004	5/8" Flat Hardened Washer	16
8		Spring Seat Spacer, (If Equipped)	4	27	47764-000	5/8"-11 UNC Locknut	8
	48902-000	1"		28		Torque Rod Shim	As Req.
	48903-000	1½"			49689-000	1/16"	
9		Spring Seat Assembly, Includes Key Nos. 10-12 <i>See Selection Guide on Page 14</i>			57856-000	1/32"	
		Left Front, Right Front (each)	1	29		Air Spring Assembly w/Upper Frame Bracket	4
		Left Rear, Right Rear (each)	1		56917-002L	HAS 40K Low Profile	
10	50918-000	5/8"-11 UNC Stud	8		50898-002	HAS 40K Low Profile (Kenworth only)	
11	22962-004	5/8" Flat Hardened Washer	8		57122-002L	HAS 40K • 46K	
12	47764-000	5/8"-11 UNC Locknut	8	30	22962-014	½" Flat Hardened Washer	4
13		Axle Bottom Cap	4	31	17700-010	½"-13 UNC Nylocknut	4
		• HAS 40K • 46K		32		Cross Channel	2
		<b>Meritor</b> RT40/41/44-145, RT46/50, RT40-160, RT46-158; <b>Dana</b> 404/405/454, DSP40/41, DSH40/44, DSS40/462/463, D40/46-170			57317-001	40" Dowel Pin Centers	
	50216-000	LHF/RHF/LHR/RHR 0-9.5° Pinion Angle			57317-002	40¼" Dowel Pin Centers	
	50222-000	LHR/RHR 10-14° Pinion Angle			57317-003	40½" Dowel Pin Centers	
		<b>Meritor</b> SSHD, RT46-157; <b>Dana</b> D402/403/451			57317-004	40⅝" Dowel Pin Centers	
	50216-000	LHF 0-9.5° Pinion Angle			57317-006	40¼" Dowel Pin Centers w/LH HCV	
	50217-001	RHF 0-9.5° Pinion Angle			57773-001	40" Dowel Pin Centers	
	50221-001	LHR 10-14° Pinion Angle			57773-002	40¼" Dowel Pin Centers	
	50222-000	RHR 10-14° Pinion Angle			57773-003	40½" Dowel Pin Centers	
		• HAS 40K • 46K			57773-004	40⅝" Dowel Pin Centers	
		<b>Dana</b> D461		33		¾"-10 UNC Bolt	4
	50085-000	LHF 0-9.5° Pinion Angle			50764-005	HAS 36K • 40K - 3" Length	
	50086-000	RHF 0-9.5° Pinion Angle			50764-003	HAS 40K • 46K - 3½" Length	
	50095-000	LHR 10-14° Pinion Angle		34		¾"-10 UNC Bolt	4
	50094-000	RHR 10-14° Pinion Angle			50764-007	HAS 36K • 40K - 2½" Length	
					50764-005	HAS 40K • 46K - 3" Length	
14		Frame Hanger Assembly	4	35	22962-001	¾" Flat Hardened Washer	16
a		HAS 40K • 46K, Includes Key Nos. 15-16		36	49842-000	¾"-10 UNC Locknut	8
	58425-001	• Standard Frame, Casting No. 57188-001, <i>Replaces 57190-001 (**14c) and 50752-001 (**14d)</i>				Lower Shock Bracket Assembly, Includes Key Nos. 37-40	4
	59045-003	• Standard Frame, Casting No. 59043-001			57356-000	HAS 36K • 40K • 46K	
	58688-001	• Rein. Frame, Casting No. 57476-001, <i>Replaces 57478-001 (**14c)</i>			49690-002	HAS 40K Low Profile	
b	50753-001	HAS 36K, Includes Key Nos. 15-17 Casting No. 49848-000 or 56666-001		37		Lower Shock Bracket	4
		<b>Slipper Pad Service Kit, One Hanger,</b> <i>See Selection Guide on Page 7</i>			57355-000	HAS 36K • 40K • 46K	
15		Slipper Pad, <i>See Selection Guide on Page 7</i>	4		49324-002	HAS 40K Low Profile	
16		Retainer Lock Pin or Screw, <i>See Selection Guide on Page 7</i>		38	50764-002	¾"-10 UNC x 5½" Bolt	4
a	58287-001	1" Lock Pin - ⅜" Diameter	8	39	22962-001	¾" Flat Hardened Washer	8
b	57540-000	⅜" Button Head Screw	16	40	49842-000	¾"-10 UNC Locknut	4
c	57306-000	⅜" Rolok Screw	16	41		Shock Absorber	4
					60670-005L	HAS 36K • 40K • 46K Standard	
					60670-007L	HAS 40K • 46K Standard Inboard Rear	
					60675-003L	Hi-Torque, <i>Replaces 57905-001</i>	
					60675-006L	HAS 40K • 46K Hi-Torque Inboard Rear	
					60670-008L	HAS 40K • 46K Low Profile	
				42	57322-001	Upper Shock Bracket Assembly, Includes Key Nos. 43-46	4
				43		**Upper Shock Bracket	1



KEY NO.	PART NO.	DESCRIPTION	VEHICLE QTY.
44	50368-000	½"-13 UNC x 3¾" Serrated Shank Bolt	4
45	22962-031	½" Flat Hardened Washer	4
46	49846-000	½"-13 UNC Locknut	4
	57430-000	<b>HCV Linkage Lower Bracket Kit,</b> Includes Key Nos. 47-50	
47	56789-000	HCV Linkage Bracket	1
48	56935-001	¼"-20 UNC x 1" Bolt, <i>Replaces 56935-002</i>	2
49	22962-028	¼" Flat Hardened Washer	4
50	49983-000	¼"-20 UNC Locknut	2
51	57977-000	Height Control Valve	1
52	58994-XXX	HCV Linkage Assembly, Specify Length, Contact Hendrickson for part no. Includes Key Nos. 53-59	1
53		**Linkage Rod, Specify Length	1

KEY NO.	PART NO.	DESCRIPTION	VEHICLE QTY.
54		**5/16"-18 UNC Jam Nut	2
55		**5/16"-18 UNC Locknut	2
56		**5/16" Flat Hardened Washer	2
57		**5/16"-18 UNC Stud	2
58		**Linkage Rod Clamp	1
59		**Adjustable Linkage Rod Joint	1
60	60218-000	**** <b>Two-Piece Transverse Torque Rod Kit,</b> Includes Bushings	2
61	22186-000	Transverse Torque Rod Frame Bracket	2
62	45045-003	Back up Plate	2
63		*Transverse Torque Rod Axle Bracket	2
	70867-001	P-80 Lubricant - 10 ml (Not Shown)	Per Bushing

### ■ HAS 46K Severe Service Kit

Severe Service Kit | Axle Set  
No. 49175-024

Reference Lit. No. SEU-0103

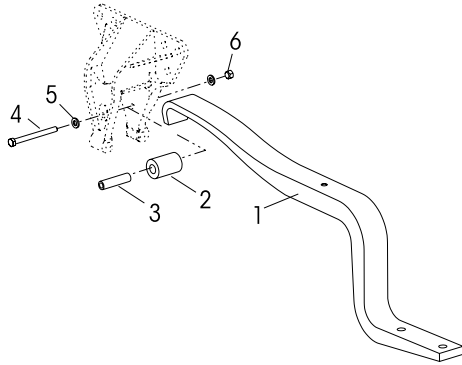

KEY NO.	PART NO.	DESCRIPTION	QTY.
		<b>Axle Set,</b> Includes Key Nos. 1-6, Frame Hanger not included	
1	59597-000	Main Support Member	2
2	59598-000	Rebound Roller	2
3	57988-000	Rebound Spacer	2
4	24531-015	½"-13 UNC x 5½" Rebound Bolt	2
5	22962-014	½" Flat Hardened Washer	4
6	49846-000	½"-13 UNC Locknut	2



KEY NO. 3		36K•40K•46K•19K•21K•23K			40K LH•12K•15K				
U-BOLT SELECTION GUIDE	<p>Approximate location for stamped part number</p>	7/8"-14 UNF 2A U-bolt			7/8" U-bolt Fastener Kit	3/4"-16 UNF 2A U-bolt			3/4" U-bolt Fastener Kit
		Part No.	Length A	Thread Length B		Part No.	Length A	Thread Length B	
		47417-001	16 1/4"	4"	*48718-157	49684-001	14"	4"	*48718-158
		47417-002	13"			49684-002	15"		
		47417-003	17 1/2"			49684-003	15 1/2"		
		47417-004	17 1/4"			49684-008	18"		
		47417-005	16 3/4"			49684-011	12 1/2"		
		47417-006	14"			49684-012	12"		
		47417-007	15"			49684-013	13"		
		47417-008	15 1/2"			49684-014	16"		
		47417-009	18"			4 1/8"	49684-015		
47417-010	19"	4"	49684-016	19"					

\* U-bolt fastener kit includes four (4) of each - spherical washer, hardened washer and locknut. Two (2) kits per axle or four (4) kits per tandem will be required to do a replacement.

HANGER SLIPPER PAD SELECTION GUIDE	SLIPPER PAD SERVICE KITS		HANGERS	
	<b>KIT NO. 56557-002</b>  KIT INCLUDES: • 1 Slipper Pad • 2 Retaining Plates • 4 Self Tapping Screws  <b>SLIPPER PAD</b> PART NO. 50612-000  		<b>CASTING NO.</b> 49676-000 49676-000 49848-000 56666-001 56669-001 56669-001 56885-001	<b>PART NO.</b> 50849- 56552- 50027-001 50753-001 56670- 50752- 56887-000
	<b>KIT NO. 56557-004</b>  KIT INCLUDES: • 1 Slipper Pad • 2 Retaining Brackets • 2 Self Tapping Screws  <b>SLIPPER PAD</b> PART NO. 56929-000  		<b>CASTING NO.</b> 57188-001 57476-001	<b>PART NO.</b> 57190- 57478-
	<b>KIT NO. 56557-005</b>  KIT INCLUDES: • 1 Slipper Pad • 2 Slotted Spring Pins  <b>SLIPPER PAD</b> PART NO. 56929-000  		<b>CASTING NO.</b> 57188-001 57476-001 57543-001 58659-001 59043-001 59050-001 59747-001	<b>PART NO.</b> 58425- 58688- 57544- 58661-001 59045- 59052-002 59768-
	<b>KIT NO. 56557-006</b>  KIT INCLUDES: • 1 Slipper Pad • 2 Roll Pins  <b>SLIPPER PAD</b> PART NO. 58959-000  		<b>CASTING NO.</b> 59050-001	<b>PART NO.</b> 59052-002

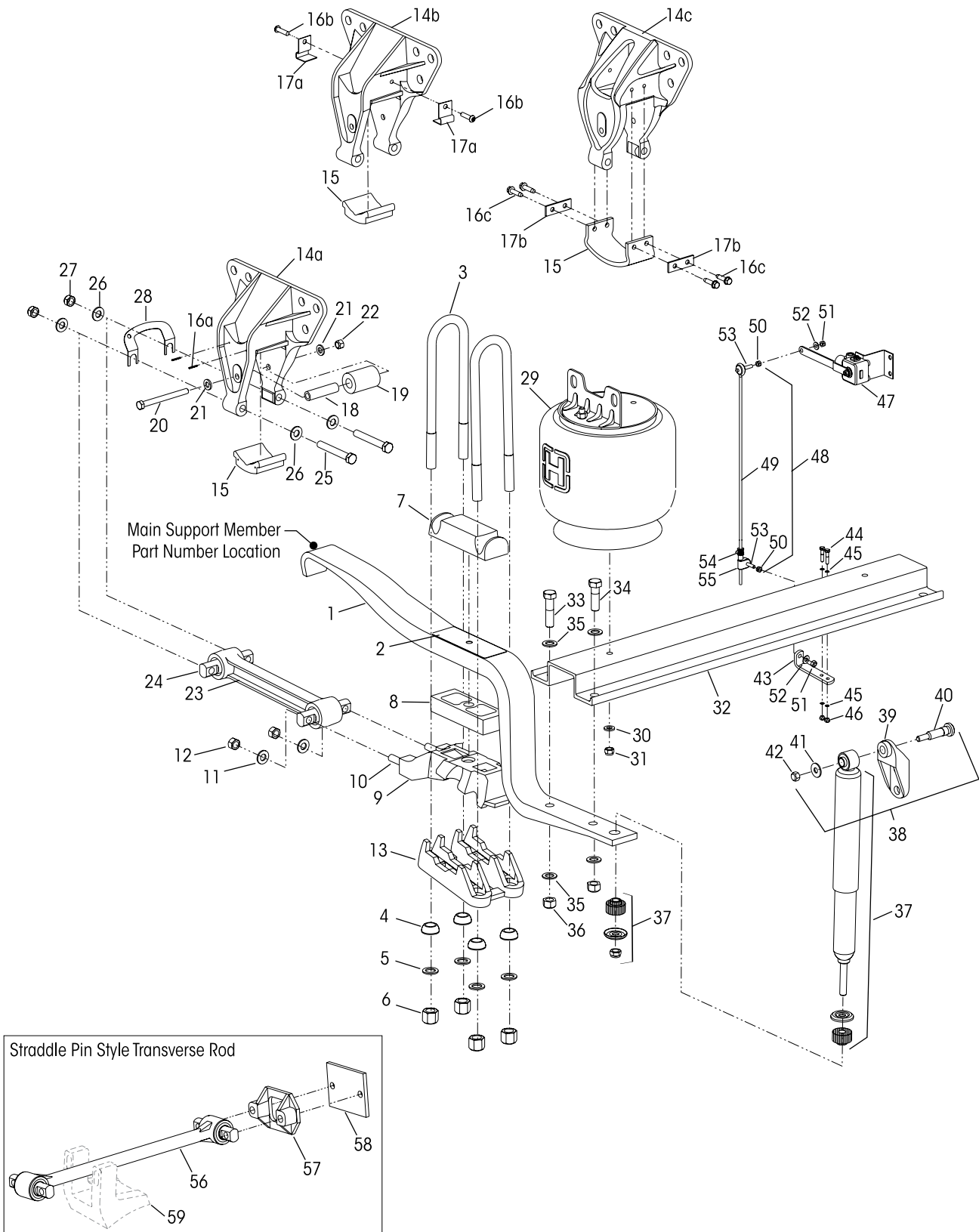





# HAS™ 40K LH Equipped with Drum Brakes

			VEHICLE				VEHICLE
KEY NO.	PART NO.	DESCRIPTION	QTY.	KEY NO.	PART NO.	DESCRIPTION	QTY.
1		Main Support Member, <i>See Part No. Location on Page 8</i>	4	18	57988-000	Rebound Bolt Spacer, <i>Replaces 47458-000</i>	4
	57217-000	Includes Key No. 2	4	19	57989-000	Rebound Roller, <i>Replaces 48883-000</i>	4
	60262-000	Mack only		20	24531-015	½"-13 UNC x 5½" Rebound Bolt	4
2	47905-000	Delrin Liner	4	21	22962-014	½" Flat Hardened Washer	8
3		¾"-16 UNF U-bolt, <i>See Selection Guide on Page 7</i>	8	22	49846-000	½"-13 UNC Locknut	4
	48718-158	<b>U-bolt Fastener Service Kit, Two U-bolts,</b> Includes Key Nos. 4-6		23	48411-006	Longitudinal Torque Rod Assembly Includes Key No. 24	4
4	49947-000	¾" Spherical Washer	16	24	47691-000L	Torque Rod Bushing	8
5	22962-001	¾" Flat Hardened Washer	16	25	32043-005	5/8"-11 UNC x 4½" Bolt	8
6	49685-000	¾"-16 UNF Locknut	16	26	22962-004	5/8" Flat Hardened Washer	16
7	56805-000	Top Pad, <i>Replaces 57195-000</i>	4	27	47764-000	5/8"-11 UNC Locknut	8
8		Spring Seat Spacer (If Equipped)	4	28		Torque Rod Shim	As Req.
	48902-000	1"			49689-000	1/16"	
	48903-000	1½"			57856-000	1/32"	
9		Spring Seat Assembly, Includes Key Nos. 10-12 <i>See Selection Guide on Page 14</i>		29	50898-002L	Air Spring Assembly w/Upper Frame Bracket	4
		Left Front, Right Front (each) 1		30	22962-014	½" Flat Hardened Washer	4
		Left Rear, Right Rear (each) 1		31	17700-010	½"-13 UNC Nylocknut	4
10	50918-000	5/8"-11 UNC Stud	8	32	57192-001	Cross Channel, 40" Dowel Pin Centers	2
11	22962-004	5/8" Flat Hardened Washer	8	33	50764-002	¾"-10 UNC x 5½" Bolt	4
12	47764-000	5/8"-11 UNC Locknut	8	34	50764-005	¾"-10 UNC x 3" Bolt	4
13		Axle Bottom Cap	4	35	22962-001	¾" Flat Hardened Washer	8
		<b>Meritor</b> RT40/41/44-145, RT46/50, RT40-160; RT46-158; <b>Dana</b> 404/405/454, DSP40/41, DSH40/44, DSS40/462/463, D40/46-170		36	49842-000	¾"-10 UNC Locknut	4
	57198-000	LHF/RHF/LHR/RHR 0-9.5° Pinion Angle		37		Shock Absorber	4
	57200-000	LHR/RHR 10-14° Pinion Angle			60680-001L	Standard	
		Dana D402/403/451			60685-001L	Hi-Torque	
	57198-000	LHF 0-9.5° Pinion Angle		38	57322-001	Upper Shock Bracket Assembly, Includes Key Nos. 39-42	4
	57197-000	RHF 0-9.5° Pinion Angle		39		**Upper Shock Bracket	1
	57200-000	LHR 10-14° Pinion Angle		40	50368-000	½"-13 UNC x 3¾" Serrated Shank Bolt	4
	57199-000	RHR 10-14° Pinion Angle		41	22962-031	½" Flat Hardened Washer	4
14 a		Frame Hanger Assembly, Includes Key Nos. 15-16 4		42	49846-000	½"-13 UNC Locknut	4
	58425-001	• Standard Frame Casting No. 57188-001, <i>Replaces 57190-001(**14b) and 50752-001(**14c)</i>			57430-000	<b>HCV Linkage Lower Bracket Kit,</b> Includes Key Nos. 43-46	
	58688-001	• Rein. Frame, Casting No. 57476-001, <i>Replaces 57478-001(**14b)</i>		43	56789-000	HCV Linkage Bracket	1
		<b>Slipper Pad Service Kit, One Hanger,</b> <i>See Selection Guide on Page 7</i>		44	56935-001	¼"-20 UNC x 1" Bolt, <i>Replaces 56935-002</i>	2
15		Slipper Pad, <i>See Selection Guide on Page 7</i>	4	45	22962-028	¼" Flat Hardened Washer	4
16		Retainer Lock Pin or Screw, <i>See Selection Guide on Page 7</i>		46	49983-000	¼"-20 UNC Locknut	2
	a	1" Lock Pin - ½" Diameter	8	47	57977-000	Height Control Valve,	1
	b	⅝" Button Head Screw	16	48	58994-XXX	HCV Linkage Assembly, Specify Length, Contact Hendrickson for Part No. Includes Key Nos. 49-55	1
	c	⅝" Rolok Screw	16	49		**Linkage Rod, Specify Length	1
17		Retaining Bracket or Plate, <i>See Selection Guide on Page 7</i>	8	50		**5/16"-18 UNC Jam Nut	2
	a	Retaining Bracket		51		**5/16"-18 UNC Locknut	2
	b	Retaining Plate		52		**5/16" Flat Hardened Washer	2
	49175-013	<b>Rebound Roller Kit, Axle Set,</b> Includes Key Nos. 18-22		53		**5/16"-18 UNC Stud	2
				54		**Linkage Rod Clamp	1
				55		**Adjustable Linkage Rod Joint	1
				56	60218-000	<b>****Two-Piece Transverse Torque Rod Kit,</b> Includes Bushings	2
				57	22186-000	Transverse Torque Rod Frame Bracket	2
				58	45045-003	Back up Plate	2
				59		*Transverse Torque Rod Axle Bracket	2
					70867-001	P-80 Lubricant - 10 ml (Not Shown)	Per Bushing

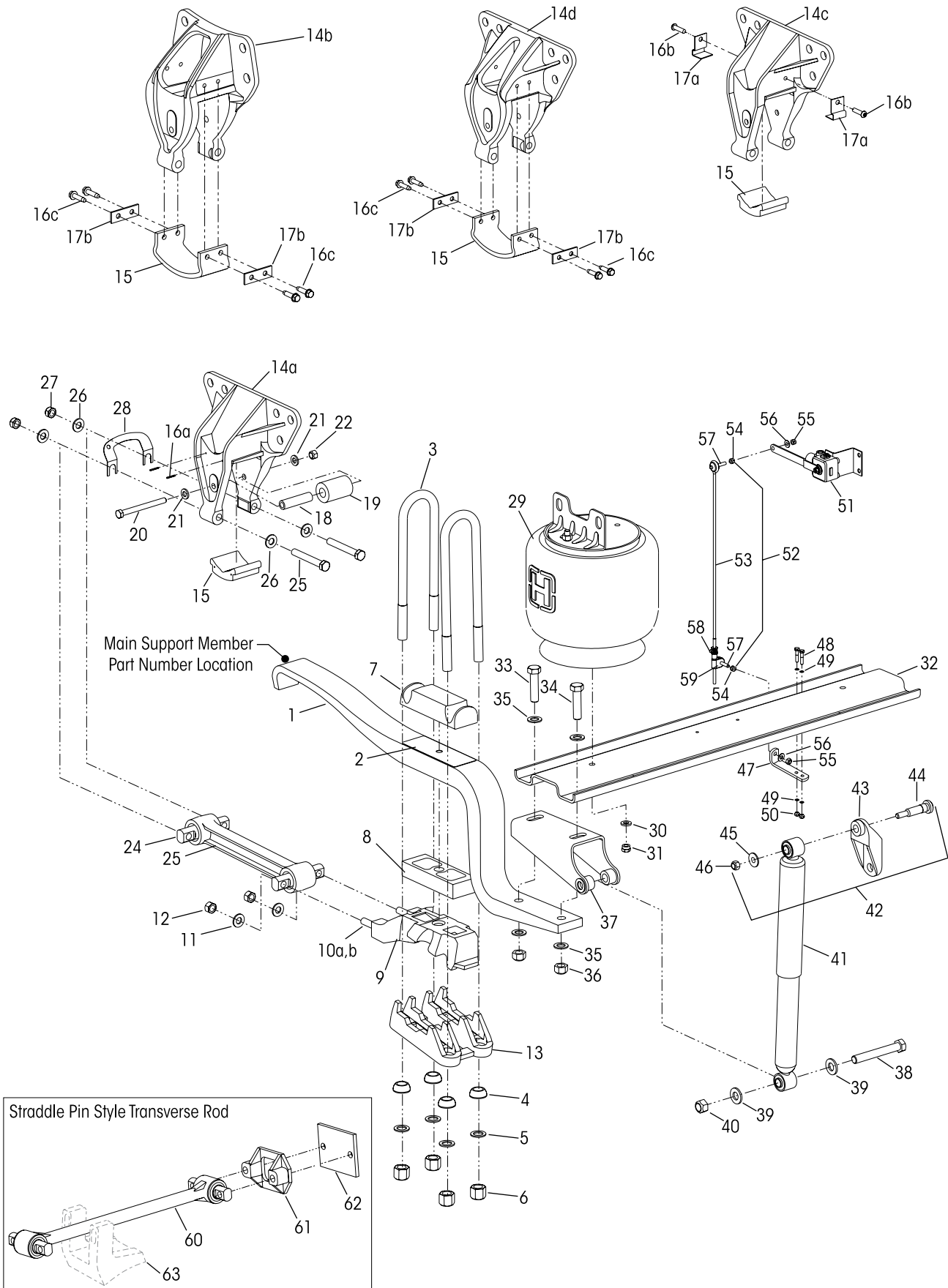



# HAS™ 12K • 15K • 19K • 21K • 23K Equipped with Drum Brakes

KEY NO. PART NO.		DESCRIPTION	VEHICLE QTY.	KEY NO. PART NO.		DESCRIPTION	VEHICLE QTY.
1		Main Support Member, Includes Key No. 2 <i>See Part No. Location on Page 10</i>	2			HAS 12K • 15K • 19K, Includes Key Nos. 15-17	
	56925-000	HAS 12K Low Profile/15K Low Profile		b	50753-001	Casting No. 49848-000 or 56666-001	
	56937-000	HAS 12K/15K			60636-001	Casting No. 60634-001	
	56928-000	HAS 19K Low Profile			59045-003	• Standard Frame, Casting No. 59043-001	
	56940-000	HAS 19K			59052-000	• Rein. Frame, Casting No. 59050-001	
	56931-000	HAS 21K Low Profile		<b>Slipper Pad Service Kit, One Hanger,</b> <i>See Selection Guide on Page 7</i>			
	56943-000	HAS 21K		15		Slipper Pad, <i>See Selection Guide on Page 7</i>	2
	56934-000	HAS 23K Low Profile		16		Retainer Lock Pin or Screw, <i>See Selection Guide on Page 7</i>	
	56946-000	HAS 23K		a	58287-001	1" Lock Pin - 1/8" Diameter	4
2	47905-000	Delrin Liner	2	b	57540-000	3/8" Button Head Screw	8
3		U-bolt, <i>See Selection Guide on Page 7</i>	4	c	57306-000	3/8" Rolok Screw	8
		3/4"-16 UNF - HAS 12K • 15K		17		Retaining Bracket or Plate, <i>See Selection Guide on Page 7</i>	4
		7/8"-14 UNF - HAS 19K • 21K • 23K		a	57566-000	Retaining Bracket	
		<b>U-bolt Fastener Service Kit, Two U-bolts,</b>		b	50597-000	Retaining Plate	
		Includes Key Nos. 4-6			49175-014	<b>Rebound Roller Kit, Axle Set,</b> Includes Key Nos. 18-22	
	48718-158	3/4" - HAS 12K • 15K		18	57988-000	Rebound Bolt Spacer, <i>Replaces 47458-000</i>	2
	48718-157	7/8" - HAS 19K • 21K • 23K		19	57989-000	Rebound Roller, <i>Replaces 48883-000</i>	2
4		Spherical Washer	8	20	24531-015	1/2"-13 UNC x 5 1/2" Rebound Bolt	2
	49947-000	3/4" - HAS 12K • 15K		21	22962-014	1/2" Flat Hardened Washer	4
	48574-000	7/8" - HAS 19K • 21K • 23K		22	49846-000	1/2"-13 UNC Locknut	2
5		Flat Hardened Washer	8	23		Longitudinal Torque Rod Assembly	2
	22962-001	3/4" - HAS 12K • 15K				Includes Key No. 24	
	22962-002	7/8" - HAS 19K • 21K • 23K			48411-006	HAS 12K • 15K • 19K	
6		U-bolt Nut	8		62007-365	HAS 23K, <i>Replaces Torque Rod 50376-001 and Bushing 57256-000</i>	
	49685-000	3/4"-16 UNF Locknut - HAS 12K • 15K		24	47691-000L	Torque Rod Bushing	4
	50765-000	7/8"-14 UNF Locknut - HAS 19K • 21K • 23K		25	32043-005	5/8"-11 UNC x 4 1/2" Bolt	4
	57347-000	7/8"-14 UNF Nylocknut - HAS 19K • 21K • 23K		26	22962-004	5/8" Flat Hardened Washer	8
7		Top Pad	2	27	47764-000	5/8"-11 UNC Locknut	4
	57224-000	HAS 12K • 15K		28		Torque Rod Shim	As Req.
	56805-000	HAS 19K • 21K • 23K			49689-000	1/16"	
8		Spring Seat Spacer (If equipped)	2		57856-000	1/32"	
	48531-009	1", HAS 12K • 15K - 6 1/4" length		29		Air Spring Assembly w/Upper Frame Bracket	2
	48902-000	1", HAS 19K • 21K • 23K - 7 3/4" length			57920-002L	HAS 12K Low Profile	
	48903-000	1 1/2", HAS 19K • 21K • 23K - 7 3/4" length			56917-002L	HAS 15K Low Profile • 19K Low Profile • 21K Low Profile • 23K Low Profile	
9		Spring Seat Assembly, Includes Key Nos. 10-12 <i>See Selection Guide on Page 15</i>			57122-002L	HAS 19K • 21K • 23K	
		Left, Right	(each) 1	30	22962-014	1/2" Flat Hardened Washer	2
10 a	50918-000	5/8"-11 UNC x 4" Stud	4	31	17700-010	1/2"-13 UNC Nylocknut	2
		for Part Nos. 50970-XXX and 50988-XXX		32		Cross Channel	1
b	32043-005	5/8"-11 UNC x 4 1/2" Hex Bolt	4			• HAS 12K	
		for Part Nos. 57033-XXX and 59795-XXX			57855-001	40" Dowel Pin Centers	
11		5/8" Flat Hardened Washer	4		57855-002	40 1/4" Dowel Pin Centers	
a	22962-004	for Part Nos. 50970-XXX and 50988-XXX			57855-003	40 1/2" Dowel Pin Centers	
b	22962-025	for Part Nos. 57033-XXX and 59795-XXX			57855-004	40 5/8" Dowel Pin Centers	
12	47764-000	5/8"-11 UNC Locknut	4			• HAS 15K • 19K • 21K • 23K	
13		Axle Bottom Cap	2		57317-001	40" Dowel Pin Centers	
		<b>Meritor</b> RS13-120, RS15-120, RS15-210			57317-002	40 1/4" Dowel Pin Centers	
	57024-000	LHF/RHF 0-5° Pinion Angle			57317-003	40 1/2" Dowel Pin Centers	
		• HAS 19K • 21K • 23K			57317-004	40 5/8" Dowel Pin Centers	
		<b>Meritor</b> RS21-145, RS21-160, RS23-160/161;			57317-006	40 1/4" Dowel Pin Centers w/LH HCV	
		<b>Dana</b> 19060/21060/21080/21090/23090/		33		3/4"-10 UNC Bolt	2
		26090, S21/23/26-170/190			50764-005	HAS 12K • 15K • 19K • 21K - 3" Length	
	50216-000	LHF/RHF 0-9.5° Pinion Angle			50764-003	HAS 23K - 3 1/2" Length	
		• HAS 23K		34		3/4"-10 UNC Bolt	2
		<b>Dana</b> 23080/23105/26015			50764-007	HAS 12K • 15K • 19K • 21K - 2 1/2" Length	
	50085-000	LHF 0-9.5° Pinion Angle			50764-005	HAS 23K - 3" Length	
	50086-000	RHF 0-9.5° Pinion Angle		35	22962-001	3/4" Flat Hardened Washer	8
	50095-000	LHR 10-14° Pinion Angle		36	49842-000	3/4"-10 UNC Locknut	4
	50094-000	RHR 10-14° Pinion Angle				Lower Shock Bracket Assembly	2
14		Front Frame Hanger Assembly,	2			Includes Key Nos. 37-40	
		HAS 21K • 23K, Includes Key Nos. 15-16			49690-002	HAS 12K Low Profile • 15K Low Profile • 19K Low Profile • 21K Low Profile • 23K Low Profile	
a	58425-001	• Standard Frame, Casting No. 57188-001, <i>Replaces 57190-001 (**14c) and 50752-001 (**14d)</i>			57356-000	HAS 19K • 21K • 23K	
	58688-001	• Rein. Frame, Casting No. 57476-001, <i>Replaces 57478-001 (**14c)</i>					

# HAS™ 12K • 15K • 19K • 21K • 23K Equipped with Drum Brakes



KEY NO.	PART NO.	DESCRIPTION	VEHICLE QTY.
37		Lower Shock Bracket	2
	49324-002	HAS 12K Low Profile • 15K Low Profile • 19K Low Profile • 21K Low Profile • 23K Low Profile	
	57355-000	HAS 19K • 21K • 23K	
38	50764-002	¾"-10 UNC x 5½" Bolt	2
39	22962-001	¾" Flat Hardened Washer	4
40	49842-000	¾"-10 UNC Locknut	2
41		Shock Absorber	2
	60670-005L	HAS 19K • 21K • 23K Standard	
	60675-003L	Hi-Torque, <i>Replaces 57905-001</i>	
	60670-010L	HAS 12K Low Profile	
	60670-003L	HAS 15K Low Profile	
	60670-008L	HAS 19K Low Profile • 21K Low Profile • 23K Low Profile	
42	57322-001	Upper Shock Bracket Assembly, Includes Key Nos. 43-46	2
43		**Upper Shock Bracket	1
44	50368-000	½"-13 UNC x 3¾" Serrated Shank Bolt	2
45	22962-031	½" Flat Hardened Washer	2
46	49846-000	½"-13 UNC Locknut	2

KEY NO.	PART NO.	DESCRIPTION	VEHICLE QTY.
	57430-000	<b>HCV Linkage Lower Bracket Kit,</b> Includes Key Nos. 47-50	
47	56789-000	HCV Linkage Bracket	1
48	56935-001	¼"-20 UNC x 1" Bolt, <i>Replaces 56935-002</i>	2
49	22962-028	¼" Flat Hardened Washer	4
50	49983-000	¼"-20 UNC Locknut	2
51	57977-000	Height Control Valve,	1
52	58994-XXX	HCV Linkage Assembly, Specify Length Contact Hendrickson for Part No. Includes Key Nos. 53-59	1
53		**Linkage Rod, Specify Length	1
54		**5/16"-18 UNC Jam Nut	2
55		**5/16"-18 UNC Locknut	2
56		**5/16" Flat Hardened Washer	2
57		**5/16"-18 UNC Stud	2
58		**Linkage Rod Clamp	1
59		**Adjustable Linkage Rod Joint	1
60	60218-000	**** <b>Two-Piece Transverse Torque Rod Kit,</b> Includes Bushings	1
61	22186-000	Transverse Torque Rod Frame Bracket	1
62	45045-003	Back up Plate	1
63		*Transverse Torque Rod Axle Bracket	1
	70867-001	P-80 Lubricant - 10 ml (Not Shown)	Per Bushing

## ■ Special Tools

### ULTRA ROD TORQUE ROD BUSHING FUNNEL TOOL



Hendrickson Part No. 66086-001L

---

**NOTE:** \* Not supplied by Hendrickson, used for reference only. Hendrickson is not responsible for components supplied by the vehicle manufacturer.  
For assistance with maintenance and rebuild instructions on these components see vehicle manufacturer.

\*\* Item included in kit/assembly only, part not sold separately.

\*\*\* These frame hangers are obsolete, although replacement slipper pads and hardware are currently still available.

\*\*\*\* Transverse torque rods are mandatory on HAS suspensions, refer to Hendrickson Lit. No. 59310-004 for mandatory use of transverse torque rods.

Hendrickson HAS ride height gauges can be obtained on-line at [www.hendrickson-intl.com/litform](http://www.hendrickson-intl.com/litform)

- **Unloaded vehicles:** Literature No. 45745-106
- **Loaded vehicles:** Literature No. 45745-050

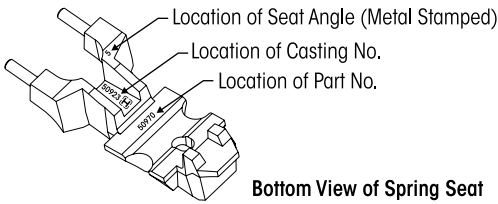

**HAS Tandem • HAS 40K LH  
Equipped with Drum Brakes**

Include fasteners. Total of four (4) spring seats are required per tandem.  
One of each located at the left / right front, and left / right rear.

HAS SPRING SEAT SELECTION GUIDE

KEY NO. 9 PAGES 5,9	LEFT FRONT			RIGHT FRONT		
	Dana D341/402/403/404/ 405/454, DSP40/41 DSH40/44 DSS40/462/463 D40/46-170	Dana D461	Dana 404/405/454, DSP40/41, DSH40/44 DSS40/462/463 D40/46-170	Dana D341/402/403		Dana D461
	Meritor SL100/SQ100, SQHD RT40/41/44-145 RT46/50-160 RT40-160 RT46-157/158,SSHD		Meritor RS21-145/160 RS23-160/161 RT40/41/44-145 RT46/50-160 RT40-160, RT46-158	Meritor SL100/ SQ100,SQHF	Meritor RT46-157, SSHD	
CASTING NO.	50923-000	50986-000	50923-000	50974-000	50974-000	50992-000
SEAT ANGLE	PART NO.	PART NO.	PART NO.	PART NO.	PART NO.	PART NO.
2°	50970-001	50988-001	50970-001	50976-001	50976-012	50994-001
2.5°	50970-002	50988-002	50970-002	50976-002	50976-016	50994-002
3°	50970-003	50988-003	50970-003	50976-003	50976-013	50994-003
3.5°	50970-004	50988-004	50970-004	50976-004	50976-017	50994-004
4°	50970-005	50988-005	50970-005	50976-005	50976-014	50994-005
4.5°	50970-006	50988-006	50970-006	50976-006	50976-018	50994-006
5°	50970-007	50988-007	50970-007	50976-007		50994-007
5.5°	50970-008	50988-008	50970-008	50976-008		50994-008
6°	50970-009	50988-009	50970-009			50994-009
6.5°	50970-010	50988-010	50970-010	50976-010		50994-010
KEY NO. 9 PAGES 5,9	LEFT REAR			RIGHT REAR		
	Dana 404/405/454 DSP40/41, DSH40/44 DSS40/462/463 D40/46-170	Dana D341/402/403		Dana D461	Dana D341/402/403/404/ 405/454, DSP40/41 DSH40/44 DSS40/462/463 D40/46-170	Dana D461
	Meritor RT40/41/44-145 RT46/50-160 RT40-160, RT46-158	Meritor SL100/SQ100, SQHP	Meritor RT46-157, SSHD		Meritor SL100/SQ100,SQHD RT40/41/44-145 RT46/50-160 RT40-160 RT46-157/158,SSHD	
CASTING NO.	50971-000	50977-000	50977-000	50995-000	50971-000	50989-000
SEAT ANGLE	PART NO.	PART NO.	PART NO.	PART NO.	PART NO.	PART NO.
5°	50973-011	50979-011	50979-013	50997-011	50973-011	50991-011
6.5°	50973-012	50979-012		50997-012	50973-012	50991-012
7.5°	50973-013	50979-014			50973-013	
8°	50973-001	50979-001		50997-001	50973-001	50991-001
8.5°	50973-002	50979-002		50997-002	50973-002	50991-002
9°	50973-003	50979-003		50997-003	50973-003	50991-003
9.5°	50973-004	50979-004		50997-004	50973-004	50991-004
10°	50973-005	50979-005		50997-005	50973-005	50991-005
10.5°	50973-006	50979-006	50979-020	50997-006	50973-006	50991-006
11°	50973-007	50979-007		50997-007	50973-007	50991-007
11.5°	50973-008	50979-008	50979-019	50997-008	50973-008	50991-008
12°	50973-009	50979-009		50997-009	50973-009	50991-009
12.5°	50973-010	50979-010	50979-015	50997-010	50973-010	50991-010
13°	50973-015	50979-017		50997-013	50973-015	50991-013
13.5°	50973-014	50979-018	50979-016		50973-014	
14°	50973-016				50973-016	



### HAS Single Equipped with Drum Brakes

Includes fasteners, total of two (2) spring seats required per single suspension.  
One of each at the left front and right front location.

HAS SPRING SEAT SELECTION GUIDE

KEY NO. 9 PAGE 11	LEFT / RIGHT			
	Dana 19060/21060/21080/21090/ 23090/26090, S21/23/26-170 /190 Meritor RS21-145/160, RS23-160/161	Dana 23080/23105/26015	Meritor RS13-120, RS15-120, RS15-210	Meritor RS13-120, RS15-120, RS15-210
CASTING NO.	50923-000	50986-000	57021-000	59793-000
SEAT ANGLE	PART NO.	PART NO.	PART NO.	PART NO.
2°	50970-001	50988-001		
2.5°	50970-002	50988-002	57033-002	
3°	50970-003	50988-003	57033-003	59795-001
3.5°	50970-004	50988-004		
4°	50970-005	50988-005	57033-005	59795-002
4.5°	50970-006	50988-006		
5°	50970-007	50988-007		
5.5°	50970-008	50988-008		
6°	50970-009	50988-009		
6.5°	50970-010	50988-010		
7°	50970-011	50988-011		

### HAS Single and Tandem 23K • 46K Equipped with Air Disc Brakes

Total of four (4) spring seats required per tandem.  
One of each located at the left / right front and left / right rear.

Bottom View of Spring Seat

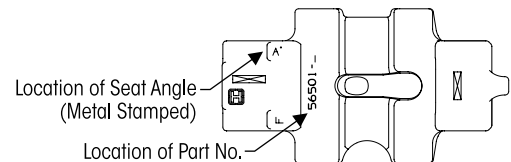

KEY NO. 9 PAGE 3	RIGHT		LEFT	
	Dana 17060, 19060, 21060, 21080, 21090, 23090, 26090, P20060, P22060, DS-402 Meritor SQ-100, SSHD, RT-40, RT-46			
CASTING NO.	56500-000		56504-000	
SEAT ANGLE	PART NO		SEAT ANGLE	PART NO
0.0°	056501-037		8.0°	70856-001
0.5°	056501-038		8.5°	70856-002
1.0°	056501-039		9.0°	70856-003
1.5°	056501-040		9.5°	70856-004
2.0°	056501-035		10.0°	70856-005
2.5°	056501-036		10.5°	70856-006
3.0°	056501-028		11.0°	70856-007
3.5°	056501-029		11.5°	70856-008
4.0°	056501-030		12.0°	70856-009
4.5°	056501-031		12.5°	70856-010
5.0°	056501-032		13.0°	70856-011
5.5°	056501-033		13.5°	70856-012
6.0°	056501-034			

This is a general parts list to provide directional information. Components may vary by model. Questions in regards to parts, contact Hendrickson Truck Parts at 1.866.755.5968 (Toll-free U.S. and Canada), 1.630.910.2800 (Outside U.S. and Canada) or e-mail: truckparts@hendrickson-intl.com.

---

[www.hendrickson-intl.com](http://www.hendrickson-intl.com)

---



Truck Commercial Vehicle Systems  
800 South Frontage Road  
Woodridge, IL 60517-4904 USA

1.866.755.5968 (Toll-free U.S. and Canada)  
630.910.2800 (Outside U.S. and Canada)  
Fax 1.630.910.2899